

EVOLUZIONE

E-340

G. MONDINI
(UK) LIMITED



Automatic Tray Sealer

The Evoluzione machines are the culmination of many years experience of working in greatly diverse applications. Whilst already securing their world wide reputation for both ruggedness and reliability, they have now been refined with even more benefits such as simpler but faster mechanisms, improved maintenance access and superior operator interfaces.

Further Enquiries: sales@gmondini.co.uk Tel. +44 (0)1785812512 Fax. +44 (0)1785 819512

EVOLUZIONE

E-340

G. MONDINI
(UK) LIMITED



•Auto out-feed



•In-feed pacer unit

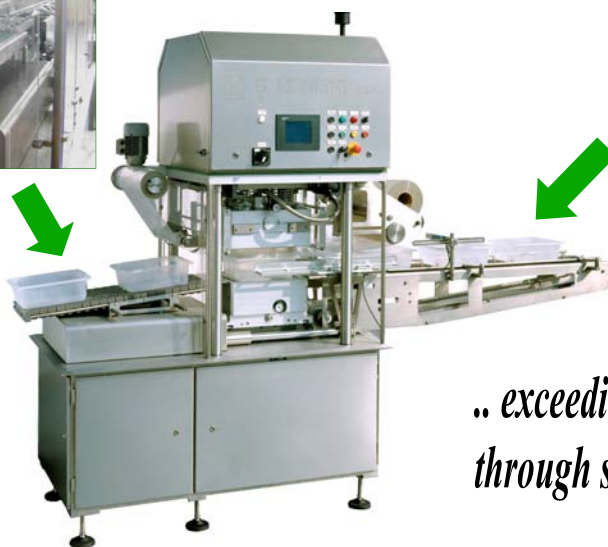

*.. exceeding packaging expectations
through simple ingenuity.*

•Sealing Performance
(packs per minute)

Type of Product	Heat Seal	Pre Cut Lid	Vac & Gas Balance < 2,5%	Vac & Gas O2 <1%	G Closure	L Closure
Solid	17	15	12,5	12,5	17	16
Liquid	10	10	8	8	10	10

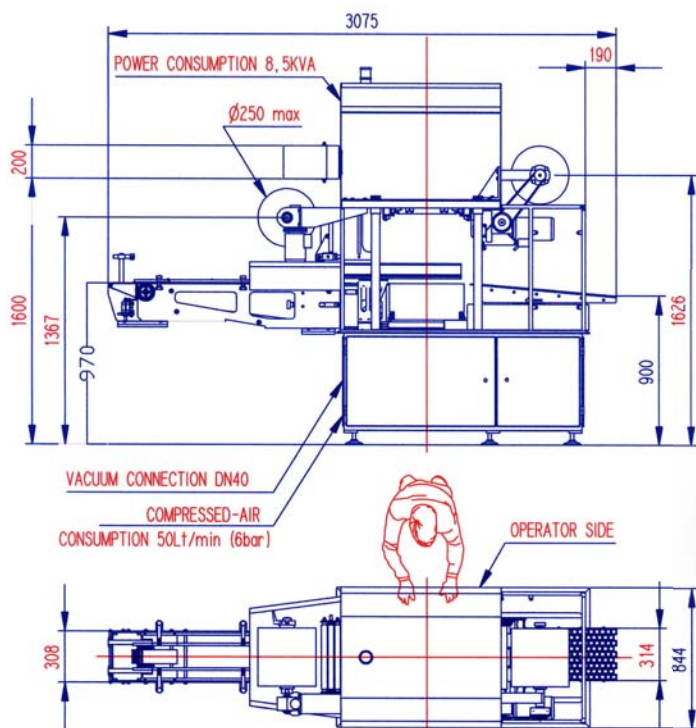

•Machine layout Diagram

- Fully Automatic Sealing Machine
- 300 x 400 Tool size
- Up-to 2 cavity sealing
- Excellent maintenance access
- 10 Minute Tool Change-over



Further Enquiries: sales@gmondini.co.uk Tel. +44 (0)1785812512 Fax. +44 (0)1785 819512